

FEATURES

- Adjustable Output Voltage
- Drives OLEDs or White LEDs
- 30V High Voltage Switch
- 1 MHz Switching Frequency
- Tiny Inductors and Capacitors
- Tiny SOT23-5L Package

APPLICATIONS

- OLED Applications
- Cell Phones
- Digital Cameras
- PDAs, Laptops
- MP3 Players
- GPS

PIN CONFIGURATION
GENERAL DESCRIPTION

The FSP3304 step-up DC/DC converter is optimized for driving OLEDs or white LEDs. It can provide an output voltage up to 24V. The device is capable of driving up to seven LEDs in series from a Lithium-Ion battery, with inherent current matching and uniform brightness.

The FSP3304 incorporates a 30V high voltage switch. The device operates at 1 MHz and allows the use of few external components. The FSP3304 is available in the tiny SOT23-5L package.

(Top View)

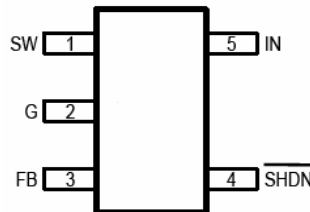

Symbol	Name	Descriptions
1	SW	Switch Output. Connect this pin to the inductor and the Schottky diode. To reduce EMI, minimize the PCB trace path between this pin and the input bypass capacitor.
2	G	Ground.
3	FB	Feedback Input. This pin is referenced to 1.24V.
4	SHDN	Shutdown Control. Connect to a logic high to enable the device. Connect to a logic low to disable the device. Never leave the pin unconnected.
5	IN	Supply Input. Bypass to G with a capacitor of 1 μ F or higher.

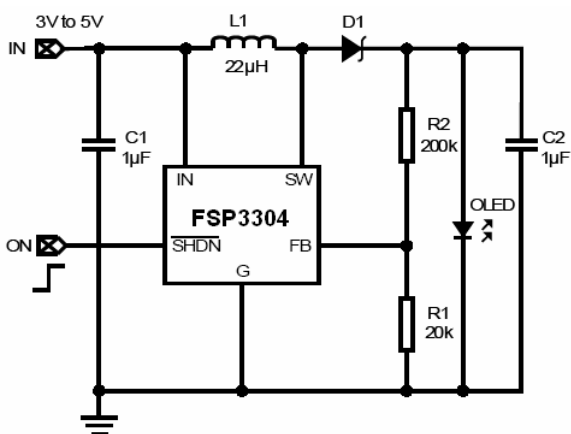
TYPICAL APPLICATION CIRCUIT

(1) Application as OLED driver

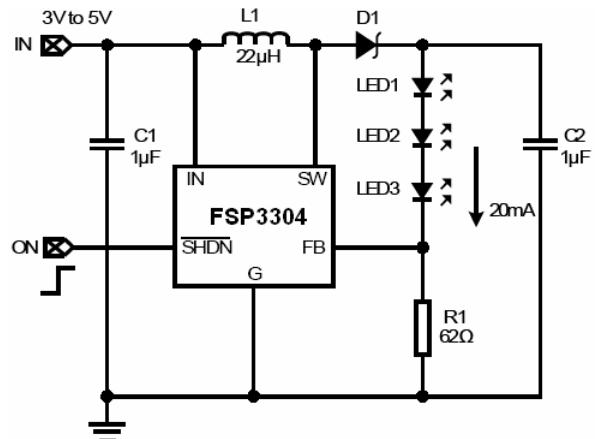

(2) Application as White LED driver

■ ABSOLUTE MAXIMUM RATINGS (NOTE)

Parameter	Rating	Unit
SW voltage	-0.3to +30	V
IN, SHDN voltage	-0.3 to +6	V
FB voltage	-0.3 to $V_{IN} + 0.3$	
Maximum power dissipation (derate 5mW/°C above $T_A=50^\circ\text{C}$)	0.4	W
Operating temperature range	-40 to +85	°C
Operating junction temperature	-40 to +150	°C
Junction to ambient thermal resistor	190	°C/W
Lead temperature (Soldering, 10sec)	300	°C

Note : Exceeding these ratings may damage the device.

■ ELECTRICAL CHARACTERISTICS

($V_{IN} = V_{SHUT}$, $T_A = 25^\circ\text{C}$, unless otherwise noted.)

Parameters	Symbol	Condition	Min	Typ	Max	Units
Input Voltage Range			2.5		5.5	V
Supply Current		SHDN=IN		0.7	1.5	mA
Supply Current in shutdown		SHDN=G		0	1	μA
Switching Frequency	f_{SW}		0.8	1	1.2	MHz
Maximum Duty Cycle	D_{MAX}		80	85		%
SHDN						
SHDN logic high threshold			1.6			V
SHDN logic low threshold					0.4	V
SHDN input current				0	1	μA
Feedback						
FB Voltage	V_{FB}	$V_{IN} = 3\text{V}$	1.18	1.24	1.30	V
FB Input Current				50		nA
Output Switch						
SW On voltage		$I_{SW} = 200\text{mA}$		350		mV
SW Current Limit	I_{LM}	Duty Cycle =70%		320		mA
Switch leakage current		$V_{SW}=20\text{V}$, SHDN=G			10	μA

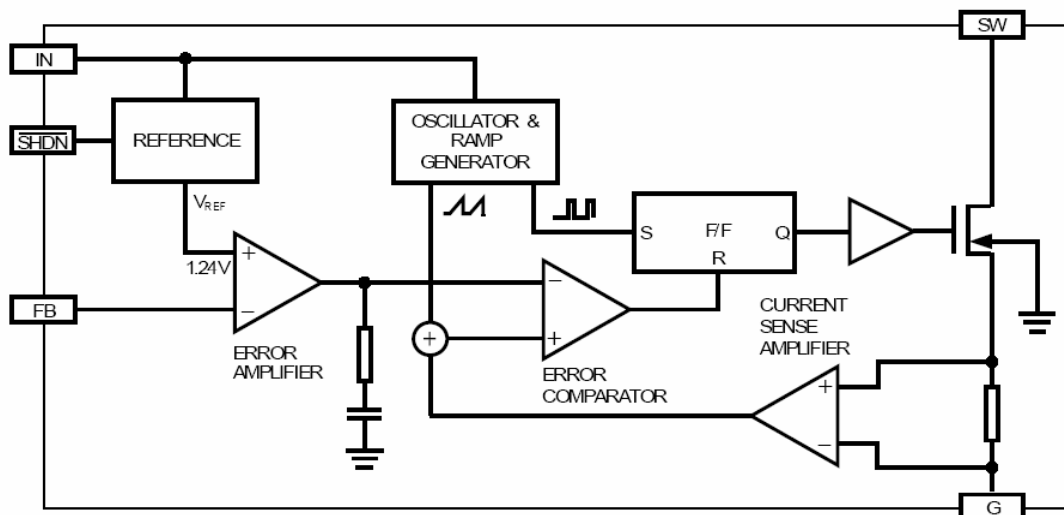
■ FUNCTIONAL BLOCK DIAGRAM

■ FUNCTION DESCRIPTION

The FSP3304 is a high efficiency step-up DC/DC converter that employs a current-mode, fixed frequency pulse-width modulation (PWM) architecture with excellent line and load regulation. The flip-flop is set at the start of each oscillator cycle, and turns on the power switch. During this on time, the switch current level is sensed and added to a ramp signal, and the resulting sum is compared with the output of the error amplifier. If the error comparator output is high, the flip-flop is reset and the power switch turns off. Thus, the peak inductor current level is controlled by the error amplifier output, which is integrated from the difference between FB input and the 1.24V reference point.

The FSP3304 operates at a constant switching frequency for output current higher than 4mA. If the output current decreases further, the IC will enter pulse skipping mode, resulting in some low frequency ripple.

■ APPLICATION INFORMATION

Inductor Selection

Table 1. Recommended Inductors

Part Number	Current Rating (mA)	DCR(>)	Supplier
CDRH3D16-220	350	0.5	Sumida
ELJPC220KF	160	4.0	Panasonic
LQH3C220	250	0.7	Murata
LEM2520-220	125	5.5	Taiyo Yuden

A 22μH inductor is typically used for the FSP3304. The inductor should have low DC resistance (DCR) and losses at 1 MHz. See Table 1 for examples of small size inductors.

Capacitor Selection

The FSP3304 only requires a 1μF input capacitor and a 1 μF output capacitor for most applications. Ceramic capacitors are ideal for these applications. For best performance, use X5R and X7R type ceramic capacitors, which possess less degradation in capacitance over voltage and temperature ranges.

Diode Selection

The FSP3304 requires a fast recovery Schottky diode as the rectifier. Select a low forward voltage drop Schottky diode with a forward current (IF) rating of 100mA to 200mA and a sufficient peak repetitive reverse voltage (VRRM). Some suitable Schottky diodes are listed in Table 2.

Table 2. Recommended Schottky Diodes

Part Number	IF (mA)	VRRM (V)	Supplier
CMDSH-3	100	30	Central
CMDSH2-3	200	30	Central
BAT54	200	30	Zetex

OLED Application

Figure 1 shows the feedback network necessary to set the output voltage. Select the proper ratio of the two feedback resistors R1 and R2 based on the desired output voltage. Typically choose R1 = 20kΩ and determine R2 from the output voltage:

$$R2 = R1 \left(\frac{V_{OUT}}{1.24V} - 1 \right) \quad (1)$$

White LED Application

The LED current is determined by the value of the feedback resistor R1. Because the FB input of the IC is regulated to 1.24V, the LED current is determined by $I_{LED} = 1.24V / R1$. The value of R1 for different LED currents is shown in Table 3. Table 3. R1 Resistor Value Selection

I_{LED} (mA)	R1 (>)
5	246
10	124
12	103.3
15	82.7
20	62

FSP3304

To improve efficiency, resistors R2 and R3 can be connected as shown in Figure 4 to lower the effective feedback voltage.

The following are dimming control methods for the FSP3304 series white LED application.

1. PWM Signal Driving SHDN

When a PWM signal is connected to the $\overline{\text{SHDN}}$ pin, the FSP3304 is turned on and off alternately under the control of the PWM signal. The current through the LEDs is either zero or full scale. By changing the duty cycle of the PWM signal (typically 1 kHz to 10kHz), a controlled average current is obtained.

2. DC Voltage Control

Figure 5 shows an application in which a DC voltage is used to adjust the LED current. The LED current increases when V_{DC} is lower than V_{FB} and decreases when V_{DC} is higher than V_{FB} .

In Figure 5, the LED current range of 15mA to 0mA is controlled by $V_{\text{DC}} = 0\text{V}$ to 2V.

3. Filtered PWM Control

Figure 6 shows an application using a filtered PWM signal to control dimming.

4. Logic Control

A logic signal can be used to adjust the LED current in a discrete step, as shown in Figure 7.

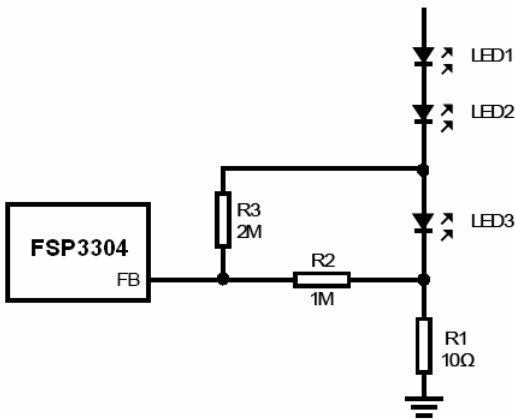

Figure 4: Current setting for white LED application

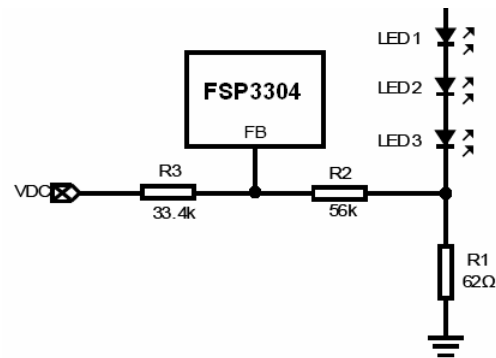

Figure 5: DC voltage controlled dimming

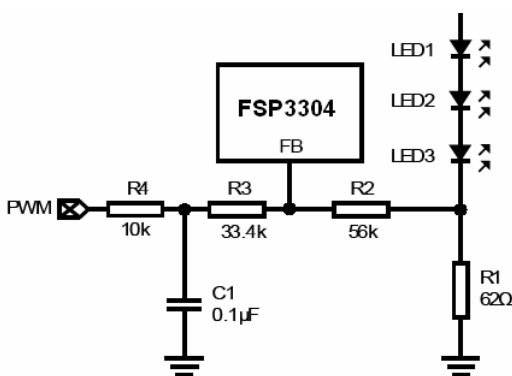

Figure 6: Filtered PWM controlled dimming

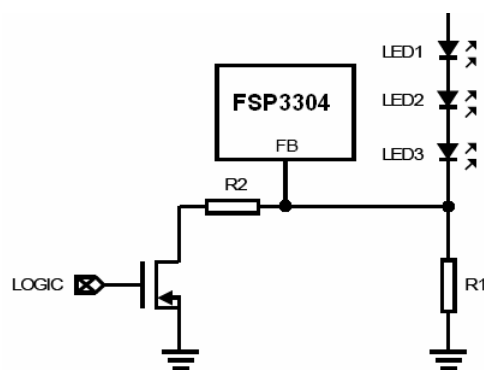

Figure 7: Logic controlled dimming

Start-up and Inrush current

In order to facilitate quick startup, a soft-start circuit is not incorporated into the FSP3304. When the IC is first turned on with no external soft-start circuit, the peak inrush current is about 400mA. Figure 8 shows an implementation for soft-start. When soft-start and dimming controls are used simultaneously, a low frequency PWM signal (less than 10kHz) or the methods in Figures 5, 6, and 7 should be used.

Open circuit protection (white LEDs)

If one of the LEDs is disconnected, the FB voltage drops to zero and the IC switches at maximum duty cycle. This results in a high voltage that may exceed the SW voltage rating. To limit this voltage, use a Zener diode as shown in Figure 9. The Zener voltage must be larger than the total forward voltage of the LEDs and the current rating should be higher than 0.1 mA.

Board layout

To reduce EMI, minimize the area and path length of all traces connected to SW. Use a ground plane under the switching regulator and connect R1 directly to the G pin of the IC.

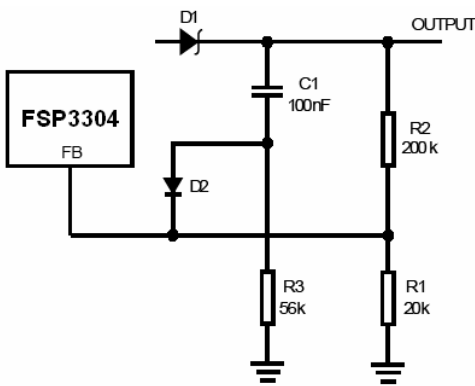

Figure 8: Soft-start circuit

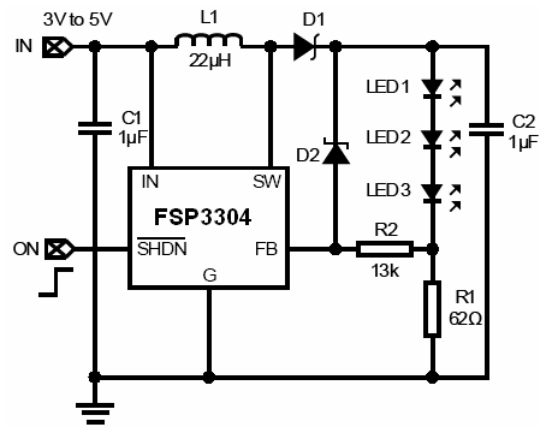
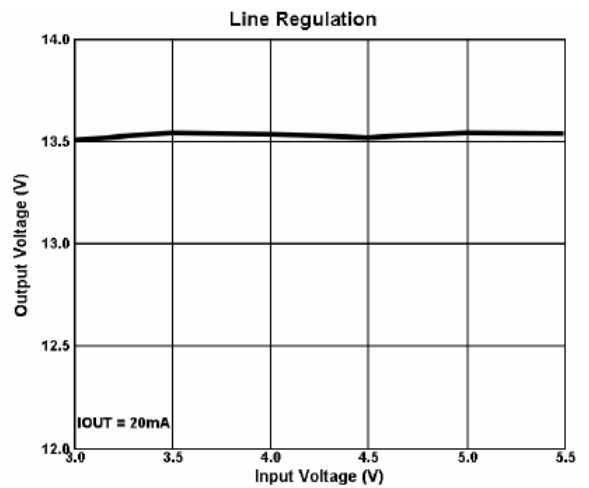
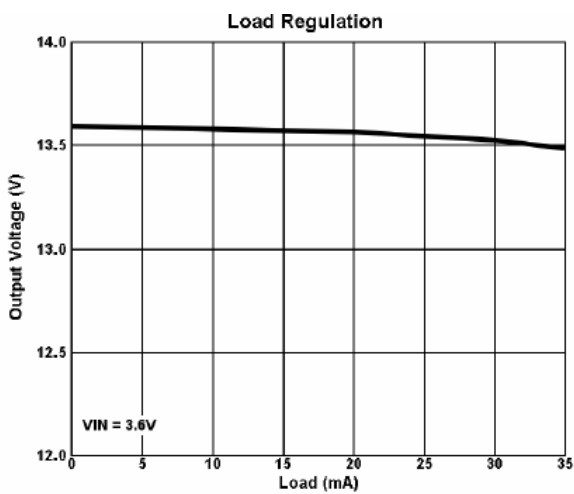
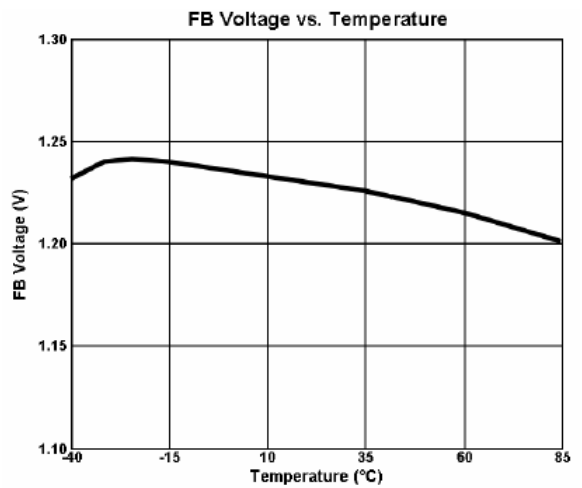
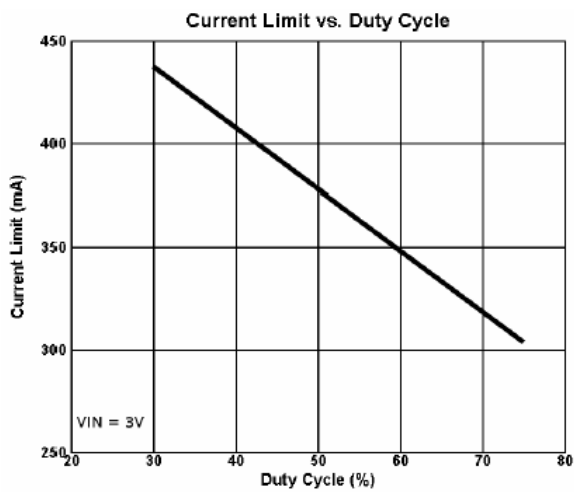
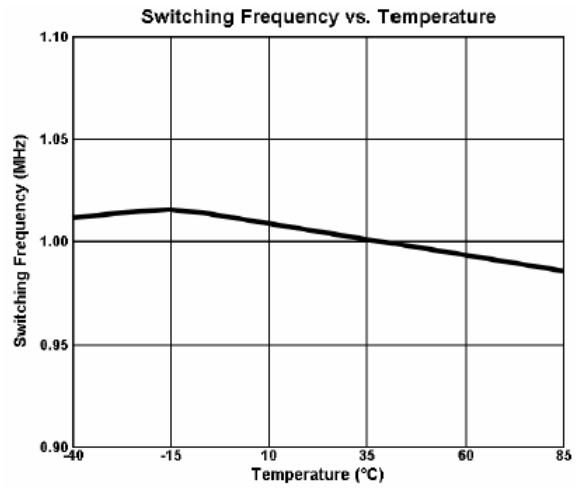
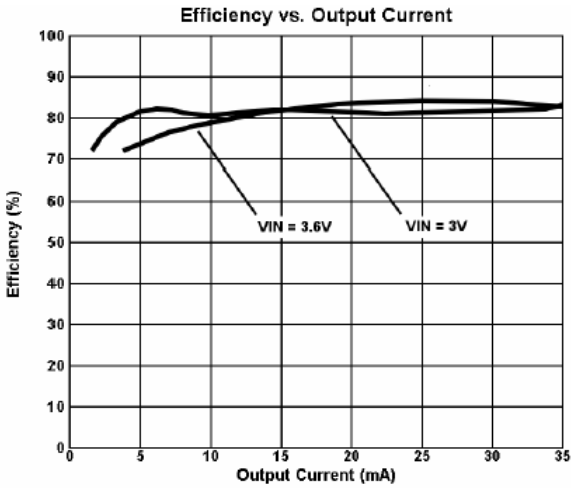

Figure 9: Open-circuit protection

■ TYPICAL PERFORMANCE CHARACTERISTICS

(circuit of figure 1, unless otherwise noted)



■ TYPICAL PERFORMANCE CHARACTERISTICS (CONTINUED)

(circuit of figure 1, unless otherwise noted)

Switching Waveform in Discontinuous Mode

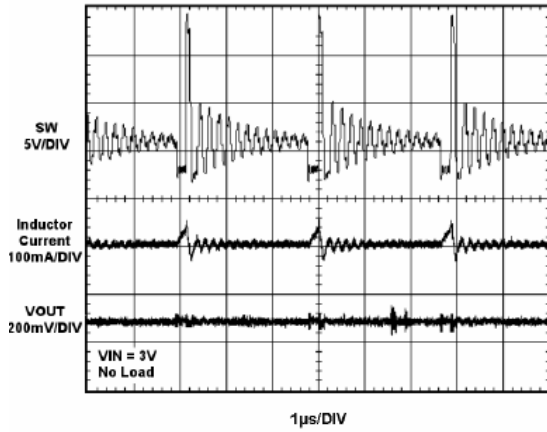

Startup without Soft Start Circuit

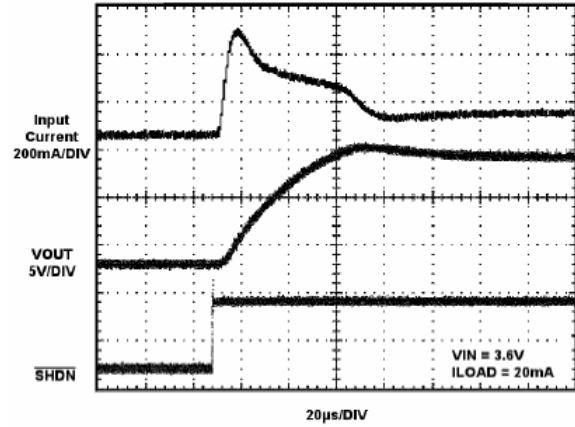

Startup with Soft Start Circuit

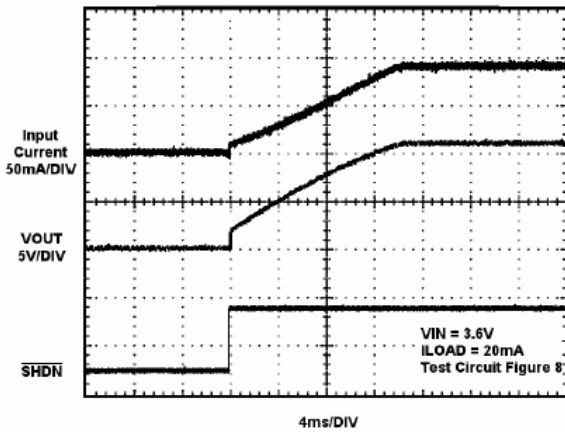

Load Step Response

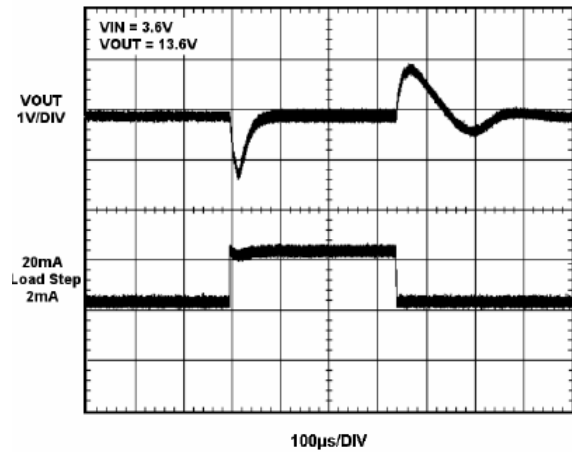

Line Step Response

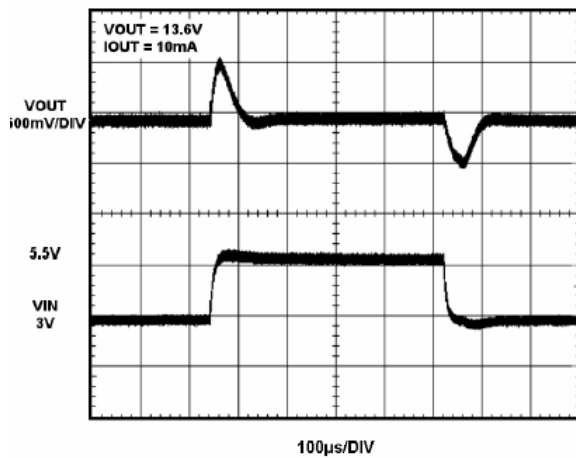

■ ORDERING INFORMATION

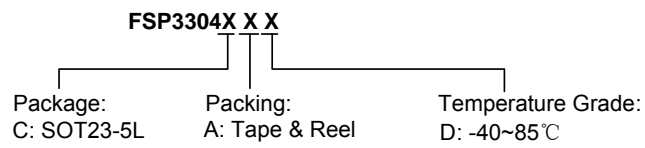

■ Marking Information

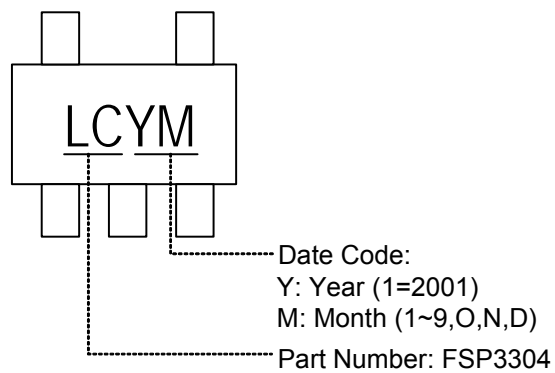

■ PACKAGE INFORMATION

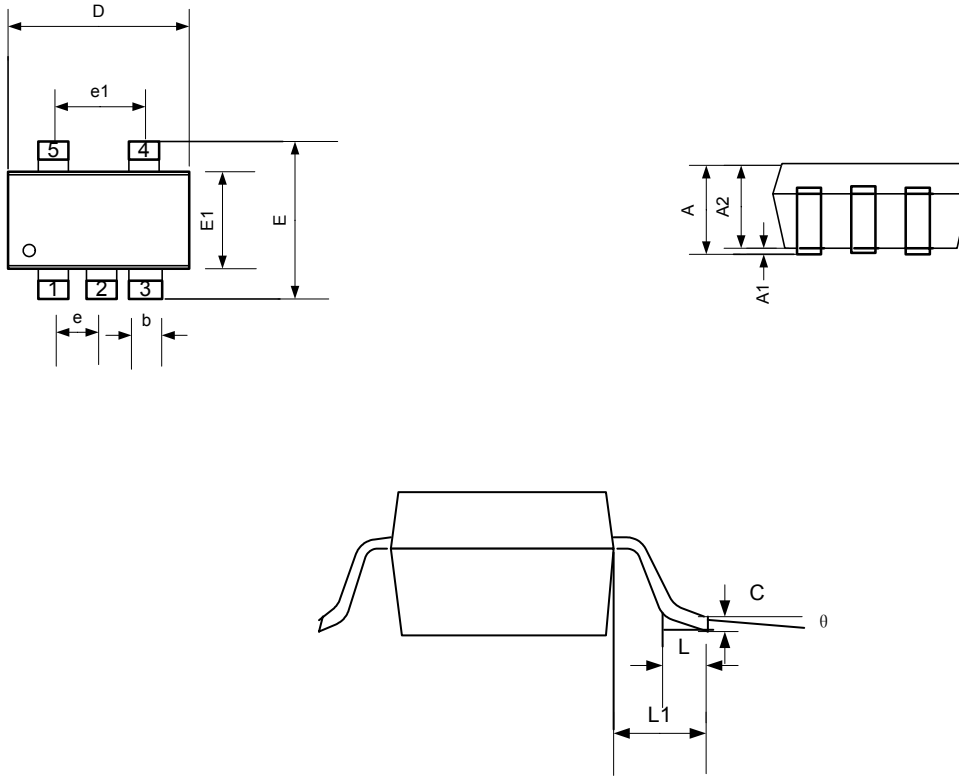

Symbol	Dimensions In Millimeters		Dimensions In Inches	
	Min.	Max.	Min.	Max.
A	1.050	1.250	0.041	0.050
A1	0.000	0.100	0.000	0.004
A2	1.050	1.150	0.041	0.045
b	0.300	0.400	0.012	0.016
C	0.100	0.200	0.004	0.008
D	2.820	3.020	0.111	0.119
E	2.650	2.950	0.104	0.116
E1	1.500	1.700	0.060	0.068
L	0.300	0.600	0.012	0.024
L1	0.700REF		0.028REF	
e	0.95 Bsc.		0.038 Bsc.	
e1	1.90 Bsc.		0.076 Bsc.	
θ	0°	8°	0°	8°